

4358-7093
8.25.16

Safety ^{1st}
onBoard™ 35 Air 360
Infant Car Seat

4-35 lb (1.8-15.9 kg) and 32 in. (81.3 cm) or less

KEEP INSTRUCTIONS
FOR FUTURE USE.

Read all instructions
before using this
child restraint.



Safety ^{1st}

www.safety1st.com

©2016 Dorel Juvenile.

⚠ WARNING:

Failure to follow the warnings on the labels and in the instruction manual can result in serious injury or death to your child.

A. Before You Begin.....Pages 3-8

- A-1 Thank You...
- A-2 Registration and Safety Notices
- A-3 Understanding Your Child Restraint

B. Safety Information.....Pages 9-10

- B-1 Vehicle Seating Position
- B-2 Installation in Vehicle
- B-3 Child Restraint Use

C. Basic Use.....Pages 11-31

- C-1 Remove and Install the Carrier to Base
- C-2 Canopy Use and Installation
- C-3 Carrier Use
- C-4 Child Restraint Use
- C-5 Preparing Child Restraint to Fit Your Child
- C-6 Securing Child in Child Restraint
- C-7 Removing Child from Child Restraint
- C-8 Reclining the Base
- C-9 Removing Harness System
- C-10 Removing Pad for Cleaning
- C-11 Installing Harness System
- C-12 Accessories on Select Models

D. General Vehicle Information.....Pages 32-37

- D-1 Understanding Your Vehicle
- D-2 Vehicle Seating Position
- D-3 Choosing LATCH or Vehicle Belts
- D-4 Knowing Your Vehicle Belts
- D-5 Aircraft Information
- D-6 Storing LATCH

E. Installing Rear Facing.....Pages 38-49

E-1 Rear Facing Installation with Base

E-2 Installing Base with LATCH



E-3 Installing Base with Vehicle Belts



E-4 Rear Facing Installation without Base

E-5 Installing Child Restraint with Vehicle Belts



General Information..... Pages 50-56

- Using a Locking Clip
- Troubleshooting
- Replacement Parts Order Form
- Replacement Parts List
- Warranty

A-1 Thank You...

Thank you for choosing this car seat, referred to throughout this manual as a child restraint. The DJG family is committed to creating a child restraint with the most comfort and convenience available today.

Remember, parents are a child's first teachers and examples. If you always buckle your seat belt, your child will think it is the natural thing to do. Make it a firm rule that the vehicle does not go until everyone is buckled up. Make no exceptions.

No one can predict if use of a child restraint will prevent injury or death in a particular crash. However, combined with careful driving, proper use of a child restraint can lower a child's risk of injury or death in most crashes.

Your child's safety is worth the time it will take to read and follow these instructions. After reading, if you still have questions or any concerns with this child restraint, please contact our Consumer Care Department at:

Dorel Juvenile Group, Inc.

Website: www.djgusa.com

Mailing Address: Dorel Juvenile Group, Inc.
Consumer Care Department
P.O. Box 2609
Columbus, IN 47202-2609

Telephone: 1-800-544-1108
8 A.M. to 6 P.M. EST M-TH
8 A.M. to 4:30 P.M. EST FRI

A-2 Registration and Safety Notices

Please complete the postage-paid registration card that came with your child restraint, and send it to us. Child restraints could be recalled for safety reasons. You must register this restraint to be reached in a recall. Send your name, address, email address if available, and the restraint's model number and manufacturing date to:

Dorel Juvenile Group, Inc.
PO Box 2609, Columbus, IN 47202-2609
Attn: Consumer Care

or call 1-800-544-1108 or register online at www.djgusa.com/registration/carseat/us.

For recall information, call the U.S. Government's Vehicle Safety Hotline at 1-888-327-4236 (TTY: 1-800-424-9153), or go to <http://www.NHTSA.gov>

A. Before You Begin

Consumer: Just fill in your name, address and email. Please print (use dark ink).

Your Name _____

Address _____

State _____ Zip _____

Email Address (optional) _____

Model Number	Model Name	Manufacture Date
BC098-BVM	DELUXE HIGH-BACK BOOSTER 65	01/22/2014

L#11 B 265035

Callouts: Model Number, Line Code, Manufacture Date

Example of model number and manufacture date.

If you don't have the card or if your address changes, you will find the model number, manufacture date, and line code on the label located on the underside of the shell.



A-3 Understanding Your Child Restraint

Front View

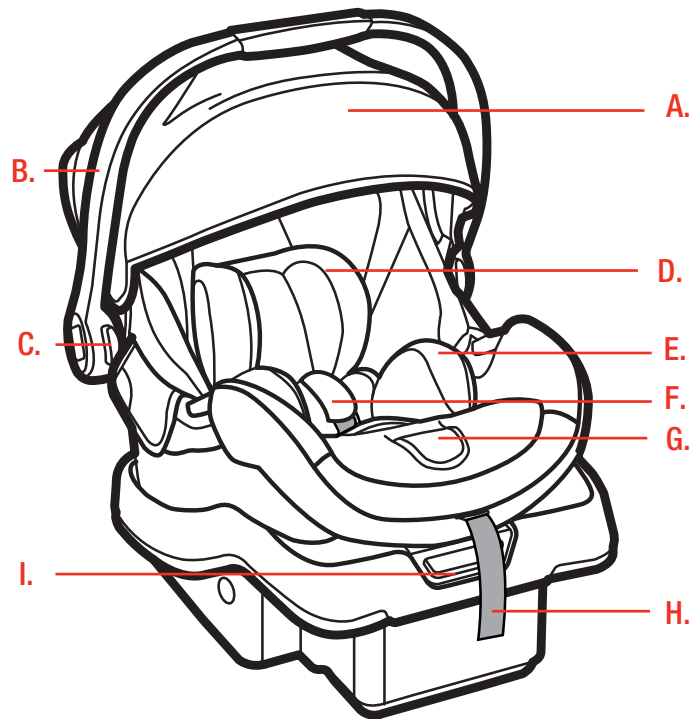

- | | |
|------------------------------------|--|
| A. Canopy | F. Harness Covers |
| B. Carry Handle | G. Harness Release Lever (under flap) |
| C. Handle Adjustment Button | H. Harness Adjustment Strap |
| D. Head Pillow | I. Base Adjustment Button |
| E. Body Pillow | |

Back View

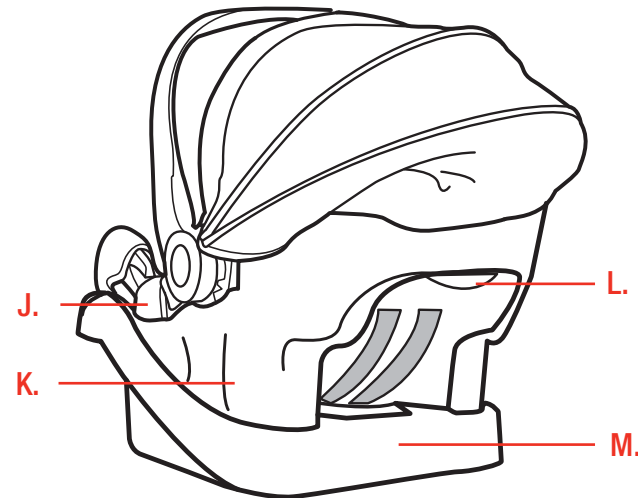

- | | |
|---------------------------|-------------------------------|
| J. Angle Indicator | L. Base Release Handle |
| K. Carrier (shell) | M. Removable Base |

A. Before You Begin

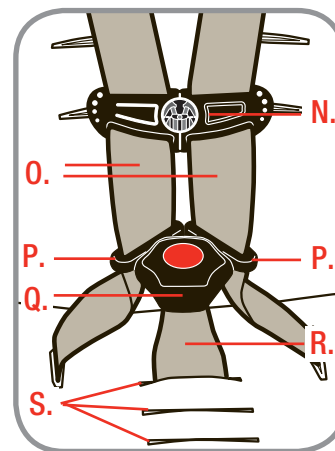

Harness System Detail

- | |
|------------------------------|
| N. Chest Clip |
| O. Harness Straps |
| P. Buckle Tongue |
| Q. Buckle |
| R. Buckle Strap |
| S. Buckle Strap Slots |

Bottom of Carrier

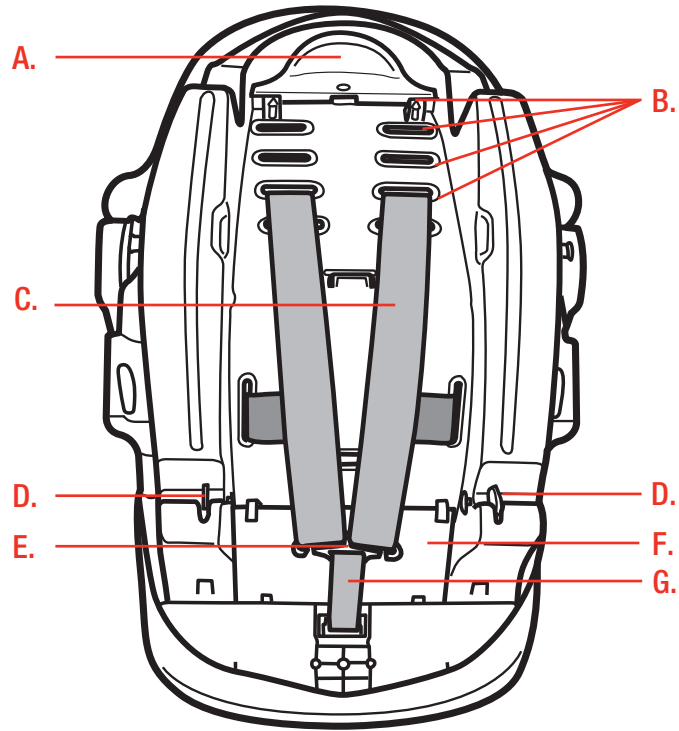

- A. Base Release Lever**
- B. Harness Slots**
- C. Harness Straps**
- D. Base Attachment Hooks**
- E. Splitter Plate**
- F. Instruction Manual Storage**
- G. Harness Adjustment Strap**

Top of Base

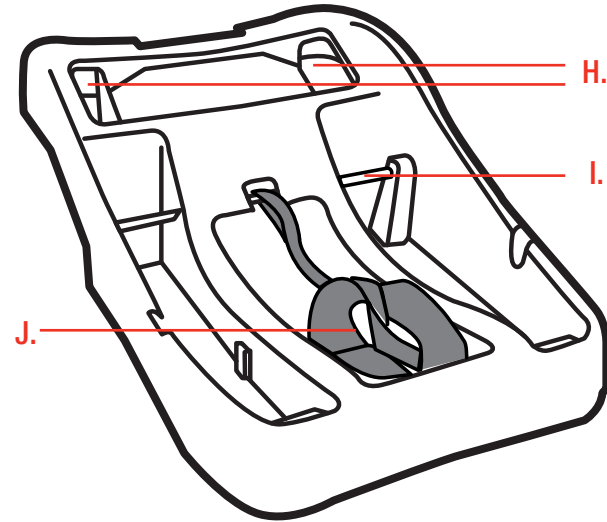

- H. Base Belt Path Openings**
- I. Base/Carrier Lock Bar**
- J. LATCH Belt Openings**

A. Before You Begin

⚠ WARNING:

Failure to follow these warnings can result in the serious injury or death of your child. To help you recognize instructions which are most critical to your child's safety, we use this symbol: ⚠

B-1 Vehicle Seating Position



⚠ **Never place a child rear facing in a seating position with an active frontal airbag.**

⚠ **Check the vehicle owner's manual for more information about airbag/child restraint use.**

⚠ **For vehicles without a back seat, refer to your vehicle owner's manual.**

B-2 Installation in Vehicle

⚠ **Check the vehicle belt or LATCH belt before each use. Use only if the belt is tightened properly and securely.**

⚠ **This child restraint should be securely belted in the vehicle even when not in use. In a crash or sudden stop, an unsecured child restraint could injure occupants.**

⚠ **Do not use a child restraint that has been in a crash. You must get a new child restraint.**

B-3 Child Restraint Use

⚠ **Never take your child out of the child restraint while the vehicle is moving.**

⚠ **Never leave child unattended.**

⚠ **Placing your child in a hot child restraint may result in burns.**

⚠ **Do not use a child restraint with damaged or missing parts.**

⚠ **Do not use cut, frayed or damaged harnesses.**

⚠ **Do not lubricate buckles and fasteners.**

⚠ **Do not substitute parts or try to modify the child restraint in any way.**

⚠ **Do not use any child restraint accessory except those approved by Dorel Juvenile Group.**

⚠ **Never allow any child to play with this child restraint; it is not a toy.**

⚠ **Do not remove or cover up any of the warning labels or other labels on the child restraint.**

⚠ **Read all instructions for additional warnings.**

⚠ **On the underside of the shell there is an expiration date for use of this child restraint. Do not use this child restraint after the expiration date.**

C-1 Remove and Install the Carrier to Base

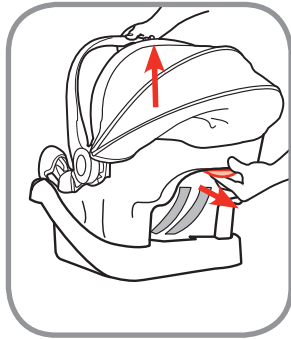

To Remove Carrier from Base

From the back of the carrier, pull the base release handle out and lift the carrier out of the base.

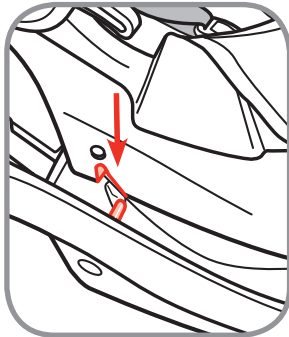

To Attach Carrier to Base

Align the notches in the front of carrier with the base lock bar.

Push down firmly to lock. You will hear a “click” when it is locked.

Pull up on carrier to make sure it is locked.

⚠ WARNING:
Failure to securely attach carrier to base can result in serious injury or death.

C-2 Canopy Use and Installation

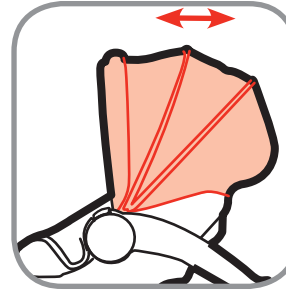

To Adjust Canopy

Grasp the front of the canopy and move it forwards or backwards to desired location.

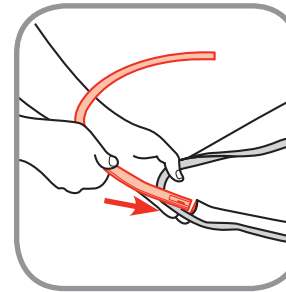

1. To Install Canopy

Completely thread the plastic strip through the tunnel in front edge of the canopy.

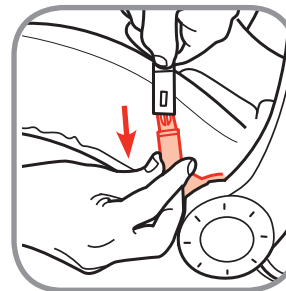

2. Attach Canopy to Carrier

Fit back of canopy over back of carrier.

Snap each plastic strip end to each canopy post.

C-3 Carrier Use

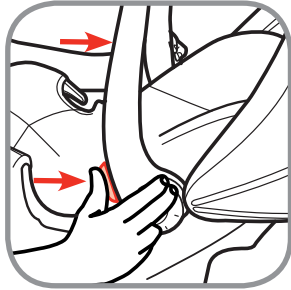

To Adjust Carrying Handle

Squeeze both adjustment buttons on each side of handle.

Rotate up or down to desired location.

Release buttons.

Make sure both handle adjuster buttons are locked.



Handle MUST be upright AND locked when carrying and when installed in the vehicle.

WARNING:



DO NOT use in the seating area or across the top of shopping carts.

WARNING:

Read ALL instructions before using child restraint as a carrier.

NEVER use carrier unless child is properly secured.

Use only as a carrier by children weighing 4-35 pounds (1.8-15.9 kg) and 32 inches (81.3 cm) or less.

NEVER leave child unattended. Always keep child within arm's reach.

Suffocation Hazard: Infant carrier can roll over on soft surfaces and suffocate child. **NEVER** place carrier on beds, sofas or other soft surfaces.

Strangulation Hazard: Children have **STRANGLER** in loose or partially buckled harness straps. Fully restrain the child even when carrier is used outside the vehicle.

Fall Hazard: Child's movement can slide carrier. **NEVER** place carrier near edges of counter tops, tables or other elevated surfaces.

Do not use the carrier if it is damaged or broken, or if any parts are missing.

C-4 Child Restraint Use

This child restraint is to be used rear facing with children weighing 4-35 lb (1.8-15.9 kg) AND 32 in. (81.3 cm) or less.

NOTE: If your child does not meet the criteria for the rear facing position, do not use this child restraint.

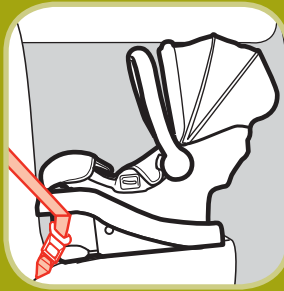

4-35 lb (1.8-15.9 kg) and 32 in. (81.3 cm) or less

Rear Facing with base:

Child and child restraint with base face the back of the vehicle and are placed in the back seat.

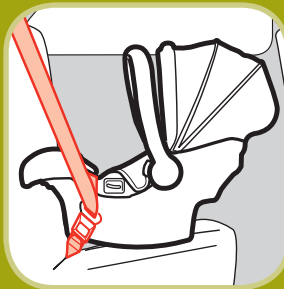

4-35 lb (1.8-15.9 kg) and 32 in. (81.3 cm) or less

Rear Facing without base:

Child and child restraint without base face the back of the vehicle and are placed in the back seat.

C-5 Preparing Child Restraint to Fit Your Child

You MUST make these adjustments with your child before you install the child restraint in the vehicle.

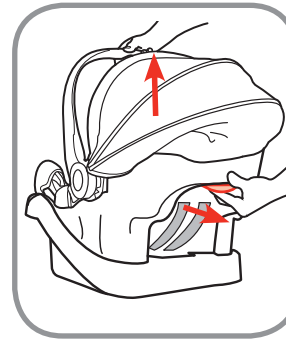

1. To Remove Carrier from Base

From the back of the carrier, pull the base release handle out and lift the carrier out of the base.

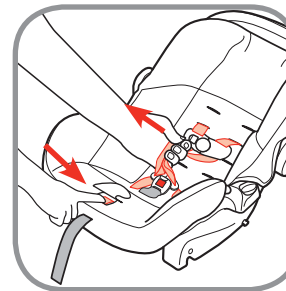

2. Loosen Harness

Push down on the harness release lever (under flap on the front of restraint) while pulling out on the harness as shown.

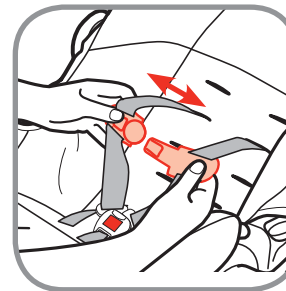

3. Release Chest Clip

Press on chest clip release button and pull apart.

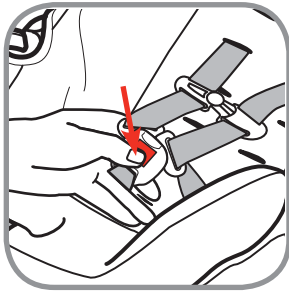

- 4. Unbuckle Harness**
 Press red button.
 Pull buckle tongues out.
 Place harness straps out of the way.



- 5. Place Child in Child Restraint**
 Place the child's bottom and back flat against the restraint.
 This will allow the harness straps to be properly tightened.



- 6. Check Buckle Position**
 Determine which of the available buckle positions will provide a snug fit for your child.

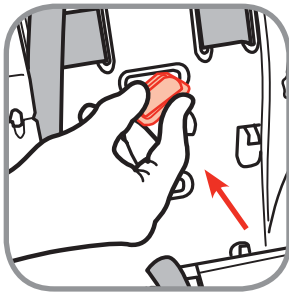

- 7. To Change Buckle Position**
 Remove child.
 From under the seat, rotate the metal retainer then insert retainer up through the carrier and pad.



- a. For small infants, skip to step c.
 Insert the buckle's metal retainer through the desired slot.
 Make sure that the buckle is **facing out**.

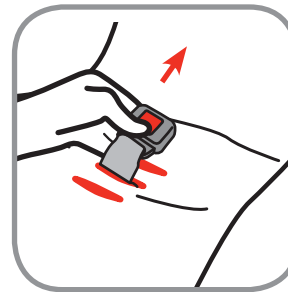

- b. Pull up on buckle strap to make sure it is secured.
The buckle must not pull out.

⚠ WARNING:
 Failure to reinstall the harness system correctly can result in serious injury or death.



- c. **Buckle Placement for Small Infants**
 Choose the slot closest to the back of the restraint.
 Push metal retainer through the pad and carrier.
 Make sure that the buckle is **facing out**.

C. Basic Use

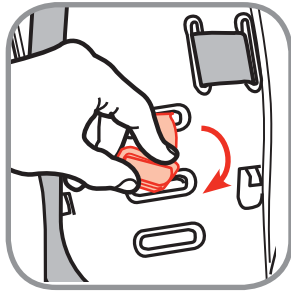

d. From the bottom, pull the metal retainer through the carrier and insert it into the middle slot.

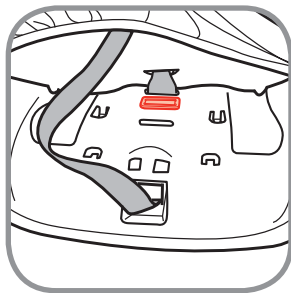

e. From the front, lift pad up and place the buckle's metal retainer flush on bottom of the carrier.
Replace the pad.

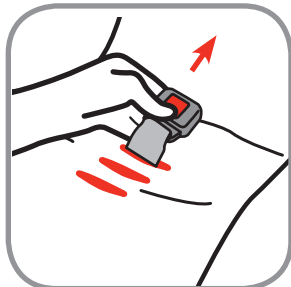

f. Pull up on buckle strap to make sure it is secured.
The buckle must not pull out.

⚠ WARNING:
Failure to reinstall the harness system correctly can result in serious injury or death.

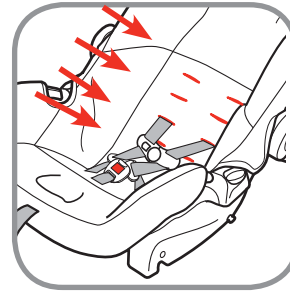

8. Check Harness Height

With child in the child restraint, check the location of the harness slot.

Follow the guidelines below to determine the correct harness height.



Rear-Facing Position
Upper harness slots must be **even with or just below** the shoulders.
If the lowest upper harness slots are above the child's shoulders, **do not** use this child restraint.



9. To Change Harness Location

With harness system loose, from the back, remove harness from the splitter plate.

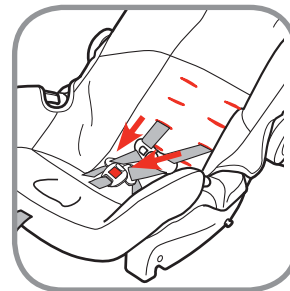

10. From the front of child restraint, pull harness straps out.

C. Basic Use

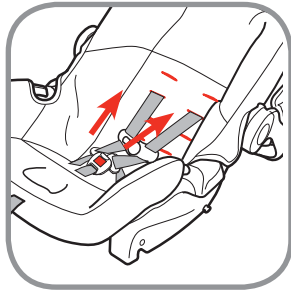

11. Rethread harness into new harness slot location.

Make sure harness straps do not twist.

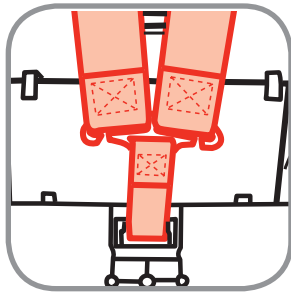

12. Attach Harness Straps to Splitter Plate

From the back of the child restraint, fit the harness strap loops onto the splitter plate.

The sewn end of the harness strap loops **MUST** face towards you. **DO NOT** twist harness

straps or harness tightening strap and make sure the harness straps are **COMPLETELY ON** the splitter plate.

⚠ WARNING:



Do not use this child restraint rear-facing if the top of your child's head is within 1 in. (2.5 cm) from the top of the child restraint.

Make sure the harness height is correct for your child's size.

Make sure you have reinstalled the harness system correctly.

Failure to follow these steps can result in serious injury or death.

C-6 Securing Child in Child Restraint

⚠ WARNING:



DO NOT put snowsuits or bulky garments on your infant when placing them in the child restraint.

Bulky clothing can prevent the harness straps from being tightened properly.

Failure to follow these steps can result in serious injury or death.



1. Position Harness Straps Over the Child's Shoulders

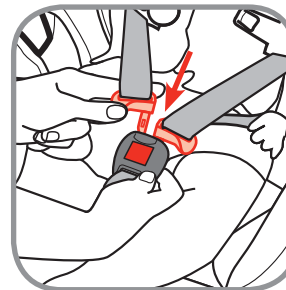

2. Buckle Harness

Push each buckle tongue into buckle until you hear a "click."

Pull up on harness straps to make sure buckle is locked.



3. Close Chest Clip
Insert right half of chest clip into left half and snap together.

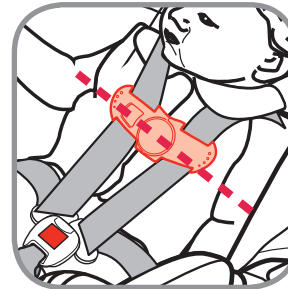

6. Position Chest Clip
The chest clip must be placed at mid-chest (even with armpits) and away from the child's neck.

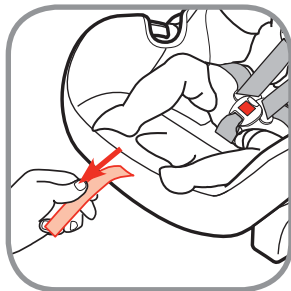

4. Tighten Harness
Pull on harness adjustment strap to tighten harness snugly.
NOTE: A snug strap should not allow any slack. It lies in a relatively straight line without sagging. It does not press on the child's flesh or push the child's body into an unnatural position.



5. Check Harness Tightness
Try to pinch the harness at the shoulders vertically between index finger and thumb.
If you can pinch the harness strap, tighten more.
If your fingers slip off, the harness is tight enough.

⚠ WARNING:

Failure to fasten and tighten the harness system correctly and snugly can result in serious injury or death.

C-7 Removing Child From Child Restraint

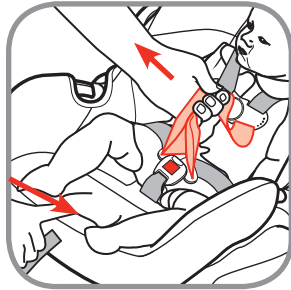

1. Loosen Harness

Push down on the harness release lever (under flap on the front of restraint) while pulling out on the harness as shown.

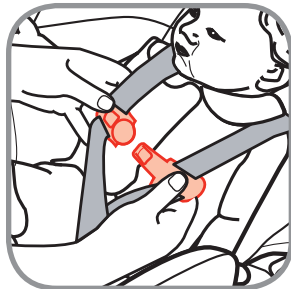

2. Release Chest Clip

Press on chest clip release button and pull apart.

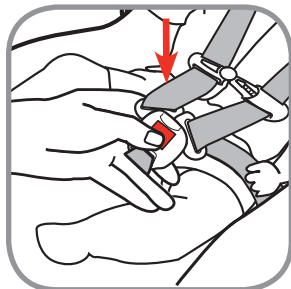

3. Unbuckle Harness

Press red button.
Pull buckle tongues out.
Place harness straps out of the way.
Remove child.

C-8 Reclining the Base

The base has multiple recline positions. Use any of these to help you achieve the recline angle needed for the weight of your child.

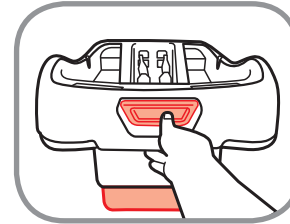

Push in on the base adjustment button and either lift or lower front of base.

C-9 Removing Harness System

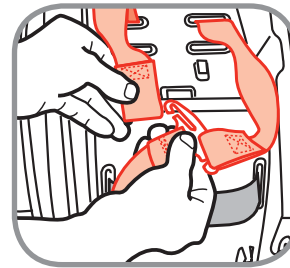

1. Remove Harness Straps from Splitter Plate

Fully loosen harness straps. Locate splitter plate on the back of the child restraint and unfasten the harness straps.

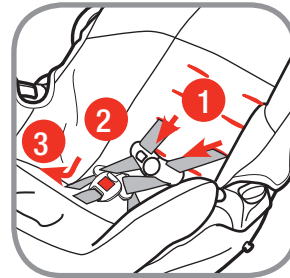

2. Remove Harness Straps

(1) Pull harness through the upper harness slots from the front.
(2) Unthread harness from the chest clip.
(3) **Do not unbuckle the buckle.** Unthread

harness from the buckle tongues.

You do not need to fully remove the harness strap from the shell.

C-10 Removing Pad for Cleaning

You must remove the harness system to remove the pad from the shell. See section C-9.

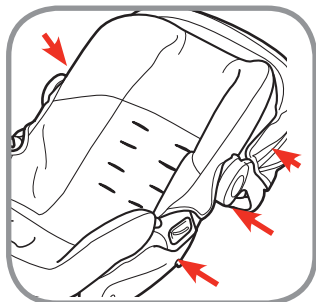

1. Release the Pad Tabs

To release the tab, pull down on the pad and pull the tab out of the carrier.

Depending on your model, unhook pad from the tabs at the top of the carrier (A).

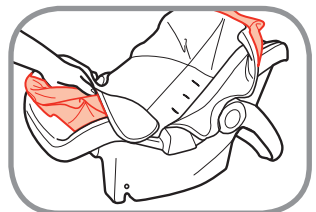
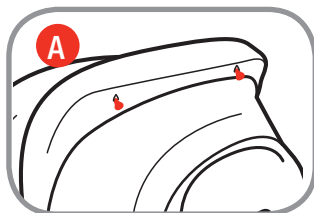
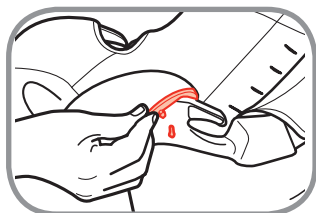

2. Remove Pad from Top and Bottom

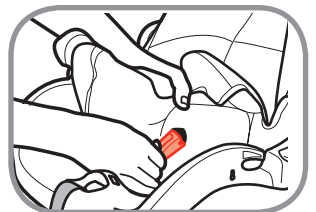

3. Pull Buckle Through Pad Remove pad.

Cleaning Pad

Machine wash separately with cold water on a gentle cycle. Do not use bleach. Tumble dry separately for 10-12 minutes on low heat. Remove immediately.

Spot clean the harness straps.

⚠ WARNING:

Do not use child restraint without the pad.

Replace child restraint pad by reversing order:

Starting from top of the child restraint, slip pad on shell.

Pull buckle and harness adjustment strap through pad.

Slip pad over front of shell.

Attach all of the tabs on the sides of shell.

Rethread harness (see section C-11).

C-11 Installing Harness System

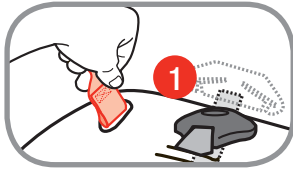

1. Thread Harness Strap

If you have fully removed the harness strap from the child restraint, **(1) with sewn end of the harness strap loop facing the buckle**, thread the harness strap down through lower harness slot on left side of shell.

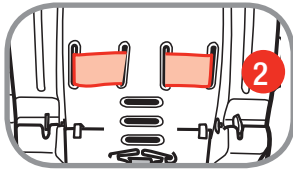

(2) Weave the harness in and out of the shell, between shell and pad, as shown.

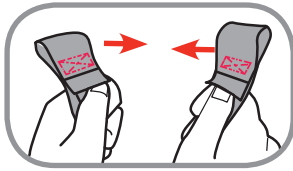

2. Take both ends of the harness strap and make them even in length.

The sewn ends of the harness strap loops **MUST** face each other as shown.

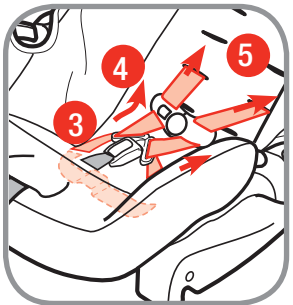

(3) Thread left harness strap through the **back** of the left buckle tongue. Repeat for right harness strap.

(4) Thread the chest clip from front to back as shown.

(5) Push harness ends through upper harness slots at same height.

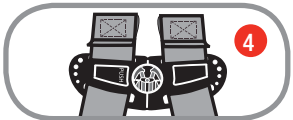

DO NOT twist harness straps.

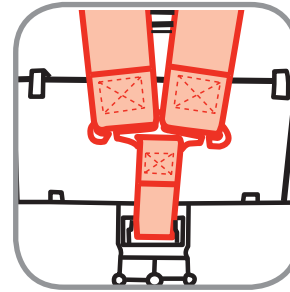

3. Attach Harness Straps to Splitter Plate

From the back of the child restraint, fit the harness strap loops onto the splitter plate.

The sewn end of the harness strap loops **MUST** face towards you. **DO NOT** twist harness

straps or harness tightening strap and make sure the harness straps are **COMPLETELY ON** the splitter plate.

⚠ WARNING:

Failure to reinstall the harness system can result in serious injury or death.

C-12 Accessories

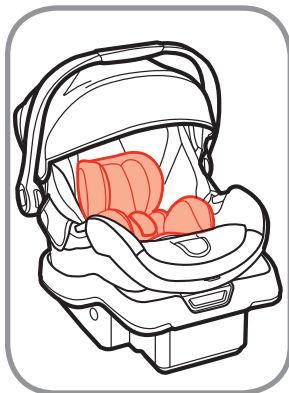

Harness Covers

Harness covers help provide comfort to the neck.

If harness covers will not allow proper positioning of the chest clip or interfere with getting a tight enough fit for a smaller baby, remove and do not use.

Store until child is large enough to use these harness covers while maintaining a properly fitting harness.

To remove harness covers, pull the fastening strips apart and remove harness covers.

Head Pillow

Loosen the harness straps.

To remove head pillow, pull it up from behind the body pillow.

You must use the body pillow in order to use the head pillow.

Body Pillow

To remove body pillow, pull buckle through the slot in bottom pillow and slide the pillow out from behind the harness straps.

D-1 Understanding Your Vehicle

Your vehicle's features may be considerably different than those pictured here. Consult your vehicle owner's manual to help identify your vehicle's specific features and locations.

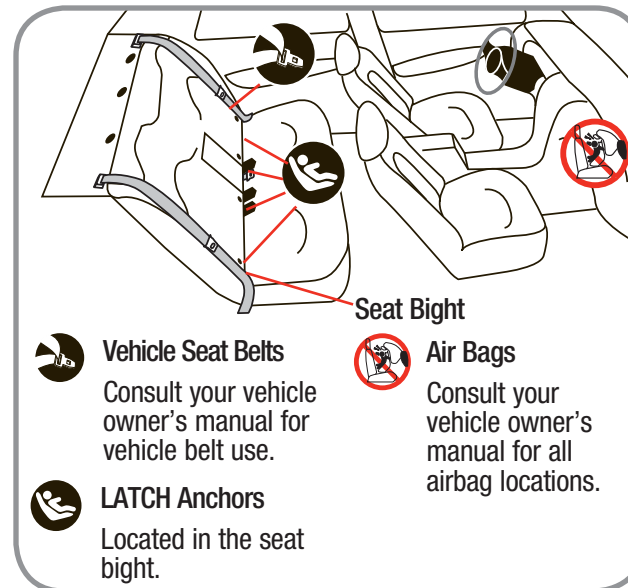

Safety Tip:

To avoid your child being seriously burned, take the following precautions:

1. Park in the shade or where sun does not directly hit the child restraint.
2. Cover the child restraint with a sheet or blanket when not in use.
3. Check for hot child restraint and buckles before placing child in child restraint.

To help protect your vehicle seat's upholstery from damage, use a single layered towel underneath and behind child restraint.

D-2 Vehicle Seating Position

Some seating positions in your vehicle may not be safe for this child restraint. Some vehicles do not have a seating position that can be used safely with this child restraint. If you are not sure where to place the child restraint in your vehicle, consult your vehicle owner's manual or contact Dorel Juvenile Group Consumer Relations Department.

⚠ WARNING:



Never place a child rear facing in a seating position with an active frontal airbag. This can result in serious injury or death.



Use the child restraint only on vehicle seats that face forward. Do not use on seats that face the sides or rear of the vehicle.

Safety Tip:



Children are safer when properly restrained in rear seating positions than in the front seating positions.

According to National Highway Traffic Safety Administration information, children in rear seating positions are statistically safer, whether you have airbags, advanced airbags, or no airbags at all.

D-3 Choosing LATCH or Vehicle Belts

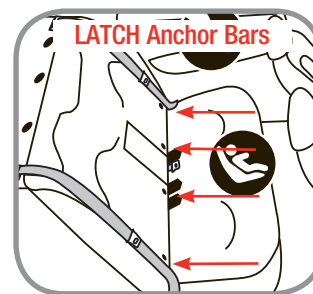

The LATCH System
 LATCH (Lower Anchors and Tethers for CHildren) is a universal system for installing child restraints without using vehicle seat belts.

The LATCH system can **ONLY** be used in vehicles that have the LATCH anchor bars installed and designated LATCH seating positions. Most vehicles manufactured after September 2002 are equipped with LATCH.

Check your vehicle owner's manual to see which seating positions may be equipped with the LATCH system.

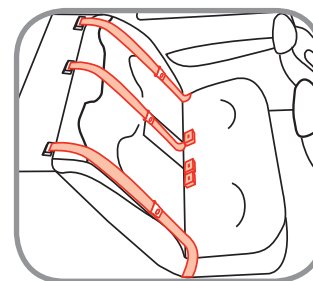

Vehicle Belts
 If LATCH is not an option, you must use the vehicle seat belt system to install the child restraint. There are some vehicle belts that will not work with a child restraint or will require special

attention. See next page and check your vehicle owner's manual for specific instructions.

⚠ WARNING:

Do not use both the LATCH belt and vehicle belt at the same time.

D-4 Knowing Your Vehicle Belts

Review your vehicle owner's manual for vehicle seat belt use with child restraints. This is your best source for information concerning your vehicle.

Not all vehicle belts will work with this child restraint. This child restraint must be tightly locked in place at all times, during travel. You must determine if your vehicles belts are compatible with this child restraint.

Vehicle Belts

- **Automatic/Passive vehicle seat belts**

You **MUST** have a vehicle lap belt to install any child restraint. An automatic (passive) shoulder vehicle belt may or may not have a separate vehicle lap belt. Consult your vehicle owner's manual.



- **Vehicle belts in center of the door or side panel**

You must move the child restraint to another seating location. Consult your vehicle owner's manual.

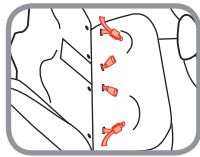

- **Vehicle belts that are in front of the seat**

You may need to move the child restraint to another seating location. Consult your vehicle owner's manual.

- **Do Not Use with inflatable seat belts**

You may need to move the child restraint to another seating location or use LATCH belts only.

- **ELR (Emergency Locking Retractor) vehicle belts**

These lap and shoulder vehicle belts only lock in a sudden stop or crash, and do not properly secure a child restraint alone. Consult your vehicle owner's manual.

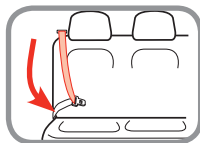

To determine if you have this type of vehicle belt, gently pull the vehicle belt all the way out of the retractor (spool), let it return several inches, then pull on it again.

If it moves freely, it is an ELR vehicle belt.

If it is locked and will not allow any more vehicle belt to come out, it is a switchable retractor.

WARNING:

ELR lap-only vehicle belts MUST NOT be used with this child restraint.

- **Switchable retractor**

These vehicle belts switch from ELR to ALR (Automatic Locking Retractor). You must have the vehicle belts in the locking mode to use them. Follow the instructions in the installation sections.

- **ALR (Automatic Locking Retractor)**

These vehicle belts lock after pulling the webbing out and letting the vehicle belt go back into the retractor an inch or two. Follow the instructions in the installation sections.

Vehicle Latch Plates

- **Check the Latch Plates**

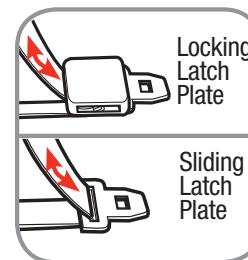

Grasp the tongue portion of the latch plate (the part that goes inside the buckle) and pull straight out, in line with the vehicle lap belt. If the latch plate does not slide up and down the vehicle belt, you have a locking latch plate. You should not need to use a locking clip. Consult your

vehicle owner's manual.

If the latch plate slides up and down on the vehicle belt, and you have an ELR retractor, you **MUST** use a locking clip to install the child restraint. You may not need to use the locking clip with a switchable or ALR retractor. Consult your vehicle owner's manual.

D-5 Aircraft Information



This restraint is certified for aircraft use.
Use only on forward-facing aircraft seats.
Follow instructions for vehicle installation.
Contact the airline for their specific policies.

D-6 Storing LATCH

⚠ WARNING:

Failure to securely store the LATCH belts can result in serious injury or death.

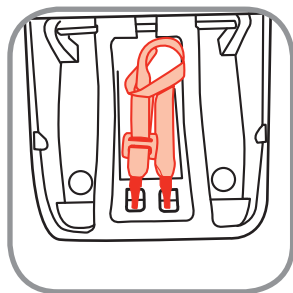

Attach LATCH Hooks to Bars in Storage Location

E-1 Rear Facing Installation with Base

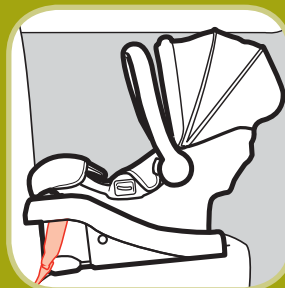

 LATCH Belt



 Lap Belt

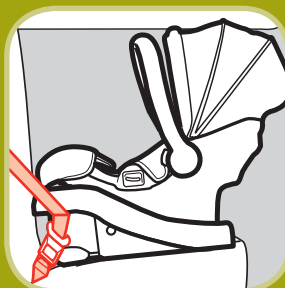

 Lap/Shoulder Belt

⚠ WARNING:



Never place a child rear facing in a seating position with an active frontal airbag. This can result in serious injury or death.

This child restraint must always face the rear of the vehicle.



E-2 Installing Base with LATCH

NOTE: Review your vehicle owner's manual for LATCH belt use.

WARNING:

Do not use LATCH along with the vehicle lap or lap/shoulder belt.

Check LATCH belt before each use. Use only if the belt can be tightened properly and securely.

Failure to follow these warnings can result in serious injury or death.



1. Place Base in Vehicle Rear Facing

Center the base between the vehicle anchors in the chosen seating position.

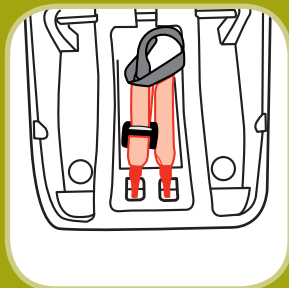

2. Remove LATCH from Storage

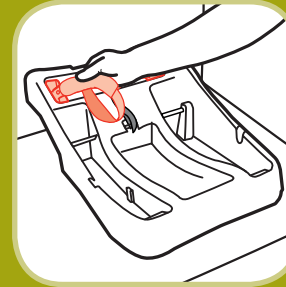

3. Thread LATCH Belt

Thread LATCH hooks through belt path openings.



4. Attach LATCH Hooks to Vehicle LATCH Anchors



5. Tighten Belt

Push base down **FIRMLY** on the base and towards the vehicle seat while pulling up on the belt to tighten.



6. Tuck Loose End of Belt

You **MUST** tuck loose end of the LATCH belt back through the belt path hole.



7. Check Belt Tightness

Grasp the base **at the belt path with one hand**. Push and pull the child restraint from side to side, forward and back. The child restraint should not move more than 1 in. (2.5 cm).

NOTE: If it moves more than 1 in. (2.5 cm), try reinstalling the child restraint or try another seating location.



8. Attach Carrier to Base

Secure child in child restraint.

Align the notches in the front of carrier with the base lock bar.

Push down firmly to lock. You will hear a “click” when it is locked. Pull up on carrier to make sure it is locked.

Carry handle MUST be upright AND locked when installed in the vehicle.

⚠ WARNING:
Failure to securely attach carrier to base can result in serious injury or death.

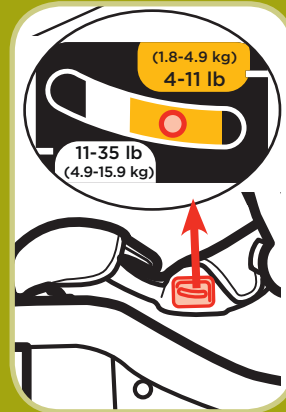

9. Check Angle Indicator

Check the angle indicator while parked on level ground. The ball should be in the zone that matches the weight of your child.

Repeat steps 3-8 if not reclined correctly and adjust base if needed (see section C-8).

You may need to place a large rolled towel or foam pool noodles under the front of the base to achieve correct recline angle.

Check often to be sure padding is still in place and the belt is tight.

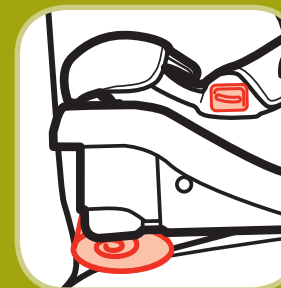



To Remove LATCH Belt From Vehicle Anchor

Remove shell from base.

Remove tension from the lower anchor belt by pushing down on side of base with the lower anchor belt adjuster. Then press the adjuster button to loosen belt.

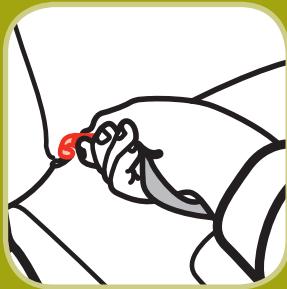

Unhook from anchor by squeezing spring lever on hook, pushing hook back into the seat bight, and twisting. Then pull it out of the vehicle seat.



E-3 Installing Base with Vehicle Belts

NOTE: Review section D-4 and your vehicle owner's manual for vehicle belt use.

⚠ WARNING:

Do not use LATCH along with the vehicle lap or lap/shoulder belt. Store LATCH when using the vehicle belts.

Check the vehicle belt before each use. Use only if the belt is tightened properly and securely.

Failure to follow these warnings can result in serious injury or death.

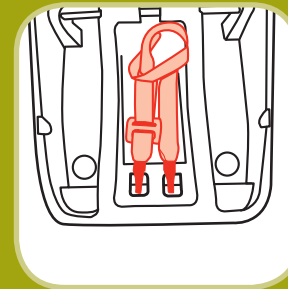

1. Store LATCH

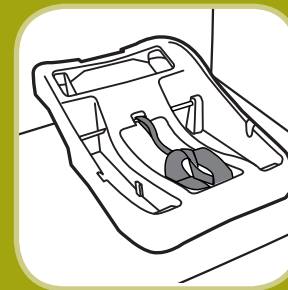

2. Place Base in Vehicle Rear Facing

Center the base in the chosen seating position.



3. Thread Vehicle Belt

Thread the vehicle lap or lap/shoulder belt combination through belt path as shown.

With an ALR belt, pull the belt all the way out before threading the base.



4. Tighten Belt

Push base down **FIRMLY** on the base and towards the vehicle seat while pulling up on the belt to tighten.



5. Check Belt Tightness

Grasp the base at the **belt path with one hand**. Push and pull the child restraint from side to side, forward and back. The child restraint should not move more than 1 in. (2.5 cm).

NOTE: If it moves more than 1 in. (2.5 cm), try reinstalling the child restraint or try another seating location.

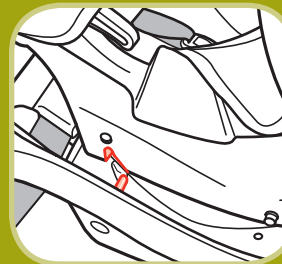

6. Attach Carrier to Base

Secure child in child restraint.

Align the notches in the front of carrier with the base lock bar. Push down firmly to lock. You will hear a “click” when it

is locked. Pull up on carrier to make sure it is locked. **Carry handle MUST be upright AND locked when installed in the vehicle.**

⚠ WARNING:
Failure to securely attach carrier to base can result in serious injury or death.



7. Check Angle Indicator

Check the angle indicator while parked on level ground. The ball should be in the zone that matches the weight of your child.

Repeat steps 3-6 if not reclined correctly and adjust base if needed (see section C-8).

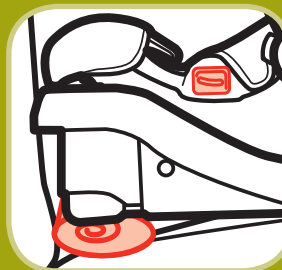

You may need to place a large rolled towel or foam pool noodles under the front of the base to achieve correct recline angle.

Check often to be sure padding is still in place and the belt is tight.

E-4 Rear Facing Installation without Base



Lap Belt

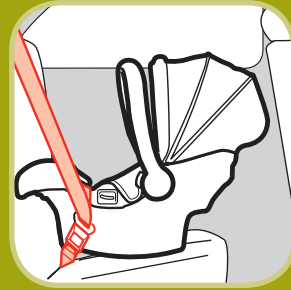

Lap/Shoulder Belt

⚠ WARNING:



Never place a child rear facing in a seating position with an active frontal airbag. This can result in serious injury or death.

This child restraint must always face the rear of the vehicle.

Do not use LATCH along with the vehicle lap or lap/shoulder belt. Store LATCH when using the vehicle belts.

Check the vehicle belt before each use. Use only if the belt is tightened properly and securely.

Failure to follow these warnings can result in serious injury or death.



E-5 Installing Child Restraint with Vehicle Belts

NOTE: Review section D-4 and your vehicle owner's manual for vehicle belt use.

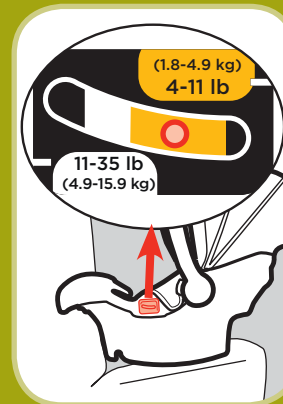

1. Place Child Restraint in Vehicle Rear Facing

Secure child in child restraint.

Center the child restraint in the chosen seating position.

Check the angle indicator while parked on level ground. The ball should be in the zone that matches the weight of your child.

2. Thread Vehicle Belt

Thread vehicle lap belt through the belt path (as shown).

Buckle the vehicle belt.

With an ALR belt, pull the belt all the way out before threading.

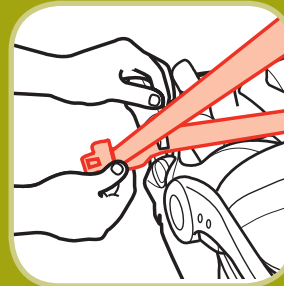

3. Tighten Vehicle Belt

Lay your forearm across child restraint at the belt path while pulling up on belt to tighten.

Feed the slack back into the retractor while tightening.



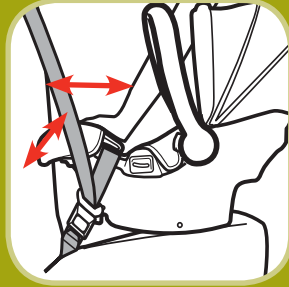

4. Check Belt Tightness

Grasp the child restraint **at the belt path with one hand**. Push and pull the child restraint from side to side, forward and back. The child restraint should not move more than 1 in. (2.5 cm).

NOTE: If it moves more than 1 in. (2.5 cm), try reinstalling the child restraint or try another seating location.

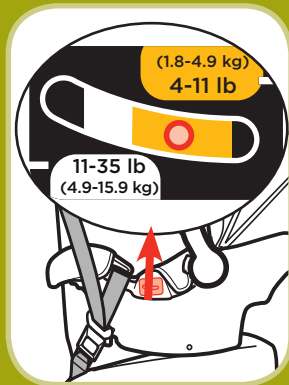

5. Recheck Angle Indicator

Check the angle indicator while parked on level ground. The ball should be in the zone that matches the weight of your child.

Repeat steps 1-4 if not reclined correctly.

You may need to place a large rolled towel or foam pool noodles under the front of the base to achieve correct recline angle.

Check often to be sure padding is still in place and the belt is tight.



Using a Locking Clip

You will rarely need to use a locking clip except for in some older vehicles. Built in child restraint locking systems have been required in vehicles since 1996, and many vehicles had these features even earlier.

Check your vehicle owner's manual to learn how to use the systems in your vehicle. If you need a locking clip, please go back to the store where you purchased this child restraint and purchase one or call us at 1-800-544-1108 to order one. Locking clips from any child restraint manufacturer are okay to use.

Remove the locking clip when the vehicle seat belt is not being used with the child restraint. **A locking clip will not fix all types of seat belt problems.**

Refer to section D-4 and your vehicle's owner manual to determine if your vehicle belts require a locking clip.

Directions below describe installing the child restraint without the base. Same steps apply for use on the base. See section E-3 or E-5 for vehicle belt step by step installation.

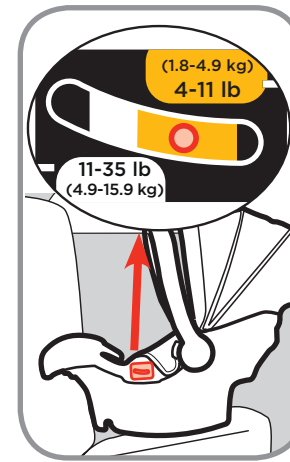

1. Place Child Restraint in Vehicle Rear Facing **Secure child in child restraint.**

Center the child restraint in the chosen seating position.

Check the angle indicator while parked on level ground. The ball should be in the zone that matches the weight of your child.

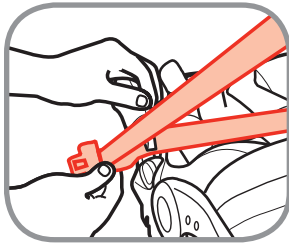

2. Thread Vehicle Belt

Thread vehicle lap belt through the belt path (as shown).
Buckle the vehicle belt.

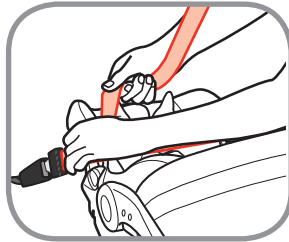

3. Tighten Vehicle Belt

Lay your forearm across child restraint at the belt path while pulling up on belt to tighten.



4. Locate Locking Clip Location

Grasp both vehicle belts together just behind the latch plate and unbuckle.
NOTE: If the latch plate ends up just at the belt path opening so you

cannot grasp the vehicle belt at the latch plate, grasp the vehicle belts on the opposite side of the child restraint, as close to the latch plate as possible.

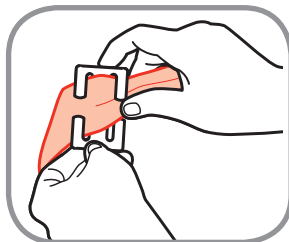

5. Attach Locking Clip

Thread both portions of the vehicle belt onto the locking clip, as close to the latch plate as possible.

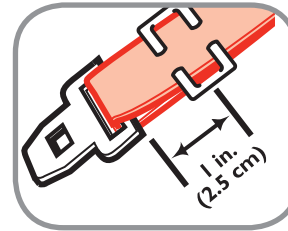

6. Position Locking Clip

Position locking clip about 1 in. (2.5 cm) from vehicle belt's latch plate.
Rebuckle vehicle belt.

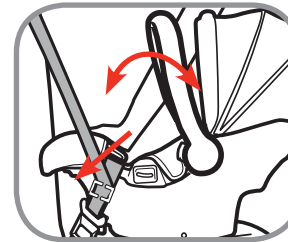

7. Check Belt Tightness

Grasp the child restraint **at the belt path with one hand**. Push and pull the child restraint from side to side, forward and back. The child restraint should not move more than 1 in.

(2.5 cm). **NOTE:** If it moves more than 1 in. (2.5 cm), try reinstalling the child restraint or try another seating location.

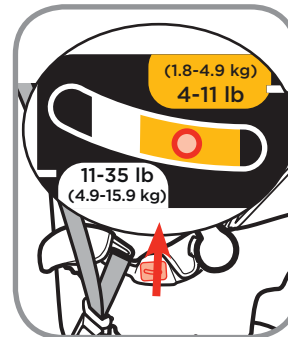

8. Recheck Angle Indicator

Check the angle indicator while parked on level ground. The ball should be in the zone that matches the weight of your child.

Repeat steps 1-7 if not reclined correctly.

You may need to place a large rolled towel or foam pool noodles under the front of the base to achieve correct recline angle.

Check often to be sure padding is still in place and the belt is tight.

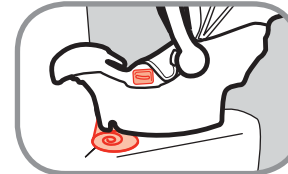

Remove the locking clip when the seat belt is not being used with a child restraint.

Troubleshooting

1. If the child restraint buckle or harness release lever sticks or you cannot get the straps tight enough around child:

DO NOT LUBRICATE. Check around lever and retractor for dropped food, sticky spilled drinks, dirt, leaves, etc. Clean with warm water and/or remove object with tweezers. If you cannot get the harness to adjust and remain tight with the buckle securely locked, do not use the child restraint.

2. If your harness twists: Straighten the harness each time you put your child in the child restraint to help prevent twisting. Lock the buckle and tighten harness and it will be ready for next use.

3 Locate a Child Safety Seat Inspection Station for hands on training on how to use your child restraint:

Visit your local Child Passenger Inspection Station or go to <http://www.nhtsa.dot.gov/cps/cpsfitting/index.cfm> to find your closest station.

Replacement Parts Order Form

Complete the form below. Your model number with color code and manufacturer date code **MUST** be included on the form to ensure proper replacement parts. Your model number with color code and the date code can be found on a sticker on the side of child restraint. Payment in U.S. dollars must accompany your order. Choose parts needed from the list on the next page.

Return the form with payment to:

**Dorel Juvenile Group, Inc.
Consumer Care Department
P.O. Box 2609
Columbus, IN 47202-2609**

Please make money orders payable to Dorel Juvenile Group, Inc. Fill in the area below to charge to Visa or Mastercard. We do not accept personal checks or Discover Card. All outside of U.S. and Canada **MUST** use credit card.

Ship To (Please Print): _____

Name: _____

Address: _____

City: _____

State/Province: _____ Zip _____

Telephone: _____

Email Address: _____

We **MUST have this information
to process your order:**

Model Number (8 to 9 characters): _____

Manufacture Date (mm/dd/yyyy): _____

Replacement Parts List

NOTE: If requested color is not available, similar color will be substituted.

Part	Cost	Quantity	Total Cost
Buckle	\$6.99	X _____	= \$ _____
Harness Strap	\$2.00	X _____	= \$ _____
Pad Set	\$27.50	X _____	= \$ _____
Chest Clip	\$1.50	X _____	= \$ _____
Locking Clip	\$2.50	X _____	= \$ _____
Base	\$39.99	X _____	= \$ _____
Instructions	\$0.00	X _____	= \$ _____

Merchandise Total \$ _____

Shipping and handling: \$ _____

Up to \$25.00	\$5.95	\$100.01 to \$150.00	\$10.95
\$25.01 to \$50.00	\$6.95	\$150.01 to \$200.00	\$11.95
\$50.01 to \$75.00	\$8.95	\$200.01 and up	\$13.95
\$75.01 to \$100.00	\$9.95	Outside Continental USA	\$10.00

Sales Tax \$ _____
 (Arizona, California, Georgia, Indiana, Missouri, South Carolina, and Texas residents add applicable sales tax.)

Grand Total \$ _____

No shipping and handling on instructions for quantities under 6. Add \$.50 for each instruction over 6, then add applicable shipping and handling.

Fill Out For Credit Card
 Visa Mastercard

Card Exp. Date: _____

Cardholder's Name: _____

Card Number: _____

Signature _____

Warranty

Dorel Juvenile Group, Inc. (DJG) warrants this product to the original retail purchaser as follows:

This product is warranted against defective materials or workmanship for one year from the date of original purchase. **An original receipt is required to validate your warranty.** DJG will, at its option, provide replacement parts or replace this product. DJG reserves the right to substitute if the part or model has been discontinued.

To make a claim under this warranty you may write to DJG, Consumer Care Department, P. O. Box 2609, Columbus, IN 47202-2609 or call 1-800-544-1108 from 8:00 a.m. to 6:00 p.m. EST Monday through Thursday and from 8:00 a.m. to 4:30 p.m. on Friday. **Proof of purchase is required and shipping charges are the responsibility of the consumer.**

Warranty Limitations: This warranty does not include damages which arise from misuse or abuse of this product.

Limitation of Damages: The warranty and remedies as set forth are exclusive and in lieu of all others, oral or written, expressed or implied. In no event will DJG or the dealer selling this product be liable to you for any damages, including incidental or consequential damages, arising out of the use or inability to use this product.

Limitation of warranties and other warranty terms and state law rights: Any implied warranties, including implied warranties of the merchantability and fitness for a particular purpose, shall be limited to the duration and terms of the express written warranty. Some states do not allow limitations as to how long an implied warranty lasts or the exclusion or limitation of incidental or consequential damages, so the above limitations may not apply to you. This warranty gives you specific legal rights, and you may have other rights, which vary from state to state. Neither DJG nor the dealer selling this product authorized any person to create for it any other warranty, obligation, or liability in connection with this product.

CUT ON DOTTED LINE